

# **MSI-5300 Load Ranger**

## **Portable Electronic Wheel Weighers from MSI**

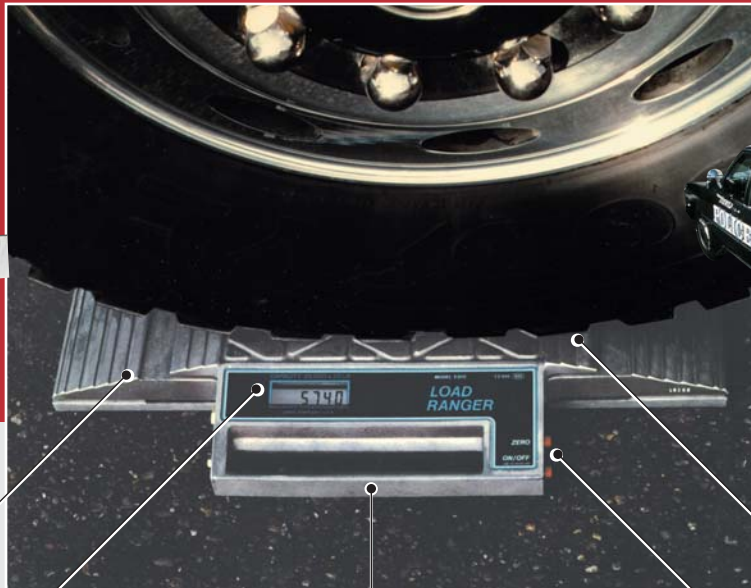
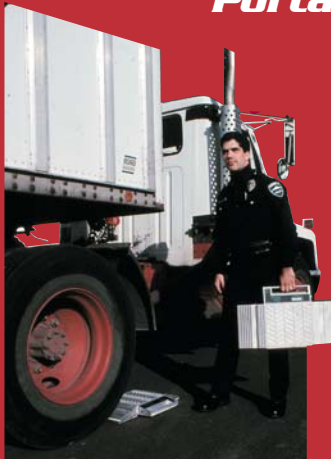

*Low profile integral ramps.  
All aluminum construction.*

*Large, easily read digits.  
Waterproof display.*

*Convenient oversized handle.*

*Sealed pushbutton switches*

*Large tire landing footprint with skid resistant surface.*

### **Spot check wheel and axle loads quickly and easily.**

#### **Weigh Your Load on the Road, at the Jobsite or Virtually Anywhere**

With concern over damage to the nation's highways, secondary streets and bridges caused by overloaded and unbalanced vehicles, state and municipal law enforcement agencies have implemented weight inspection programs to help ensure highway safety and protect taxpayer investment. Weight inspections are typically administered at roadside stations along major highways by utilizing large capacity fixed base truck scales. Unfortunately, it has been cost prohibitive to apply these same inspection methods along secondary roads.

However, there exists a cost effective alternative for exercising accurate and spontaneous inspection programs virtually anywhere with the MSI-5300 Load Ranger Portable Wheel Weigher. Through the use of portable wheel/axle weighers, weight inspections can be administered at a fraction of the cost associated with large fixed truck scales.

#### **The Load Ranger**

The MSI-5300 Load Ranger was primarily designed for mobile weight enforcement programs. Fast, accurate measurements of wheel and axle loads can be made virtually anywhere on a



variety of road surfaces. Extremely light weight and compact, Load Ranger allows weight inspection stations to be set up within minutes.

Law enforcement is not the only consumer group to benefit from Load Ranger's portability. Many commercial

freight and handling related companies utilize Load Ranger to ensure compliance with axle load requirements before they set out on the nations highways – avoiding costly overload fines and jeopardizing insurance coverage.

The Load Ranger is tested and approved to NTEP Class III standards (Certification #90-129P). Each wheel pad is environmentally sealed from outside influences and has a 10-ton loading capacity. Integral ramps and a low profile allow easy on / off vehicle loading. Pushbutton controls and a digital display provide for simple operation and easy reading. Power is supplied by a 6-volt rechargeable battery allowing up to 40 hours of continuous use between charges.

Accessories include a battery charger for quick recharging of up to four (4) batteries simultaneously from either 115/230 VAC or 12 VDC vehicle power, portable aluminum carrying cases and replacement batteries.

## MSI-5300 Load Ranger Specifications

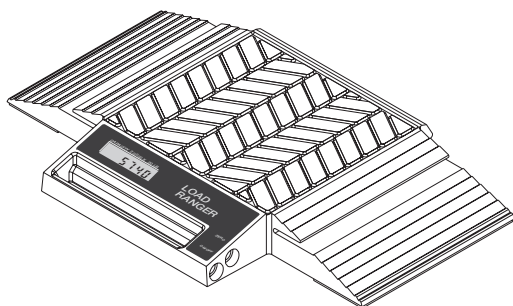
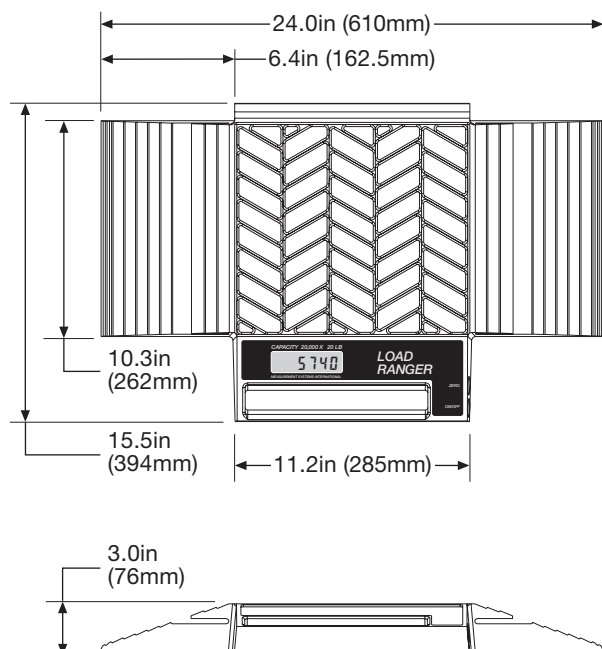

- Accuracy: 1.0% Approved to NTEP, Class III Standard
- Capacity: 20,000 lb (10,000kg) per pad
- Resolution: 20 lb (10kg), 50 lb (20kg) - NTEP
- Power: 6 volt rechargeable (40 hours between charging)
- Battery Charger: 115/230 VAC External, 12 VDC External
- Display: 5 digit, 0.8in (20mm) Liquid Crystal
- Annunciators: Low Battery
- Operating Temperatures: -25° to 140°F (-32° to 60°C)
- Safe Overload: 150% of capacity
- Ultimate Overload: 200% of capacity
- Overall Weigh Pad Dimensions: 24.0in x 15.5in x 3.0in (610mm x 394mm x 76mm)
- Enclosure: Environmentally sealed, NEMA 4/IP65, corrosion resistant cast aluminum
- Weight: 43 lb (19kg) per pad
- Options: NTEP approved version (20,000 x 50 lb capacity per pad)
- Accessories:
  - Universal Battery Charger, 115/230 VAC or 12 VDC power input (charge up to 4 batteries simultaneously from either 115/230 VAC or 12 VDC vehicle power)
  - Replacement 6 volt rechargeable battery
  - Portable aluminum carrying cases (available for 2, 4, and 6 pad systems - contact factory)

### Your Performance Guarantee

Load Ranger is backed by MSI's exclusive limited warranty and is guaranteed to perform to your highest expectations. Quality sales and service are provided by MSI's worldwide network of factory-authorized

distributors. Your local distributor can present free product demonstrations and provide answers to your specific weighing application.

*If you would like additional information on the MSI-5300 Load Ranger, other*

*MSI products or to locate the distributor nearest you, please contact MSI at 206-433-0199, toll free at 800-874-4320 (USA and Canada) or visit our website at [www.msiscales.com](http://www.msiscales.com).*

*"We weigh quality first"*

**Measurement Systems International**

14240 Interurban Avenue South STE.200  
Seattle, Washington 98168-4661 U.S.A.  
Phone: 206-433-0199 • Fax: 206-244-8470  
Web: [www.msiscales.com](http://www.msiscales.com) • Email: [info@msiscales.com](mailto:info@msiscales.com)



Specifications subject to change without notice.

PUB.356-12-07 Printed in U.S.A.

© 2008 by Measurement Systems International, Inc.